

HENGSTLER



Especially Safe
and Compact:

New Generation of Absolute Encoders

- "Industry" Series
- "Drive" Series

HENGSTLER
ACURO



New Generation of ACURO Encoders: Enhanced Safety in Function and Application

Absolute encoders follow the latest trend: Change easily to ACURO

Absolute encoders save costs and provide enhanced safety – facts that are obviously important in complex installations and multi-axis machinery: Time-consuming reference runs after powering-up the supply voltage have become a thing of the past for absolute encoders. Hazardous conditions caused by reference runs (which are always necessary with incremental encoders) can be prevented right from the start.

Absolute encoders – too large, too expensive? A prejudice that is cleared up by ACURO. Even the multiturn version of ACURO is no larger than most incremental encoders and costs less than you would expect!

And how about reliability?

Due to their complexity, absolute encoders seem to be susceptible to faults. No problem with ACURO: Once installed they will not cause trouble due to the highest integration density and use of extremely reliable technologies to ensure safe and reliable long-term operation.

The Platform Concept

Hengstler's new ACURO absolute encoders feature innovative technology, simple operation and optimal functional safety. Their platform concept allows especially compact dimensions with a modular design, which always ensures the right version for each individual application in the field of motor feedback and automation engineering. Equipped with the new open BiSS interface these encoders are a good and future oriented investment.

The mechanical construction of ACURO is rugged and precise. Double high-precision ball bearings guarantee reliable long-term operation even at speeds of up to 12,000 rpm. ACURO is equipped with all the commercially available mechanical interfaces, including solid shaft or hub shaft, synchro-flange or clamping flange. ACURO is the right match for a wide range of applications – from medical

technology, elevators, all printing, paper processing or metal-processing machinery, such as presses and saws, right through to highly-dynamic drives.

Latest OptoASIC-Technology

The key element of the ACURO encoder is an OptoASIC, which has been customized for Hengstler. This sensor forms the basis for both industrial encoders and motor feedback encoders.

It has been designed to withstand high thermal stress in motor feedback applications and to meet the industrial requirements for ruggedness, as well as mechanical and electrical compatibility. The multiturn version of ACURO with a mechanical gearbox excels with quiet running and OptoASIC scanning. It will be your best choice for applications requiring positioning detection over several axis rotations. The mechanical gearbox with lower installation height than that of a battery-based solution offers excellent EMC, is maintenance-free at continuous input speeds up to 10,000 rpm, and non-susceptible to magnetic interference.

The singleturn and multiturn versions are based on a common ACURO safety concept that ensures continuous overall system safety.

ACURO multiturn encoders are capable of transmitting up to 4,096 absolute turns (12 bits) to the control unit.

Special features of ACURO Absolute Encoders

- Unique integrated safety and monitoring concept
- Non-susceptible to magnetic interference
- Compact sizes
- Preset Key
- Diagnostics LEDs
- Extremely high single-turn resolution (more than 4 million increments/turn)
- Robust signals at operating temperatures from -40°C to +100°C or -15°C to +120°C

- Especially low power consumption (approx. 1/3 of the usual values)
- Supply input is protected against over-voltage and reversed polarity
- Short-circuit resistant output
- Parameterization of resolution and code direction.

New: Preset Key and Diagnostics LED

ACURO absolute encoders are supplied with a standard preset key, which offers various benefits:

- No mechanical encoder adjustment required, this means reduced installation time.
- Easier use of absolute encoders (calculation of offset values in the control unit no longer required)
- Recessed preset key for protection against inadvertent operation.
- Preset key can be disabled via ACURO soft, our PC configuration and diagnostics tool.
- Immediate monitoring of encoder functions by means of diagnostics LED ensures shorter startup times.



Integrated OptoASIC

ACURO OptoASIC

- Latest technology
- One-chip design of the complete encoder electronics
- Ensures high operating safety and compact design
- 22 Bit singleturn resolution with interpolation, adjustable via configuration menu.



Safety in every Detail: Diagnostics and Alarm Concept

Warning is better than alarming...

ACURO encoders are designed for longevity and reliability. At Hengstler, the term reliability also includes the ability to detect system faults as early as possible and report them to the control unit via a warning Bit. So, if necessary, this will give you sufficient time to have your encoder exchanged during the next regular maintenance – an important factor especially in the processing

industry, where system or installation shut-downs are associated with extremely high costs. Ultimate fault conditions are signaled by a separate alarm Bit. Therefore, maintenance intervals can be prolonged and long-term operating safety is ensured. Separate output of warnings and alarm messages via field bus, BiSS* or extended SSI protocol.

Moreover, the operating status of the encoder – including the operating temperature – can be retrieved at any time via the interface. The temperature can also be monitored by means of limit values, which are stored in the encoder: ACURO will send a warning or alarm message as soon as an upper or lower limit has been exceeded.

** fully digital bidirectional sensor interface*

The Elements of the ACURO Safety Concept

Contamination Safety

Code errors, which may be caused by contamination, condensation or mechanical overload, are safely recognized and evaluated by means of a plausibility check. This code check ensures that the encoder signal reflects the acquired angular position precisely, Bit-by-Bit. Possible contamination of the optical system, damage of the encoder disk or the end of the LED life are detected reliably and signaled by a warning or alarm message.

Robust internal and external communication

For additional reliability of all relevant data, the digital interfaces are internally secured between the singleturn sensor, multiturn module and bus interface, and externally checked via BiSS by means of CRC (cyclic redundancy check) in the protocol.

Safety Concept of ACURO Encoders

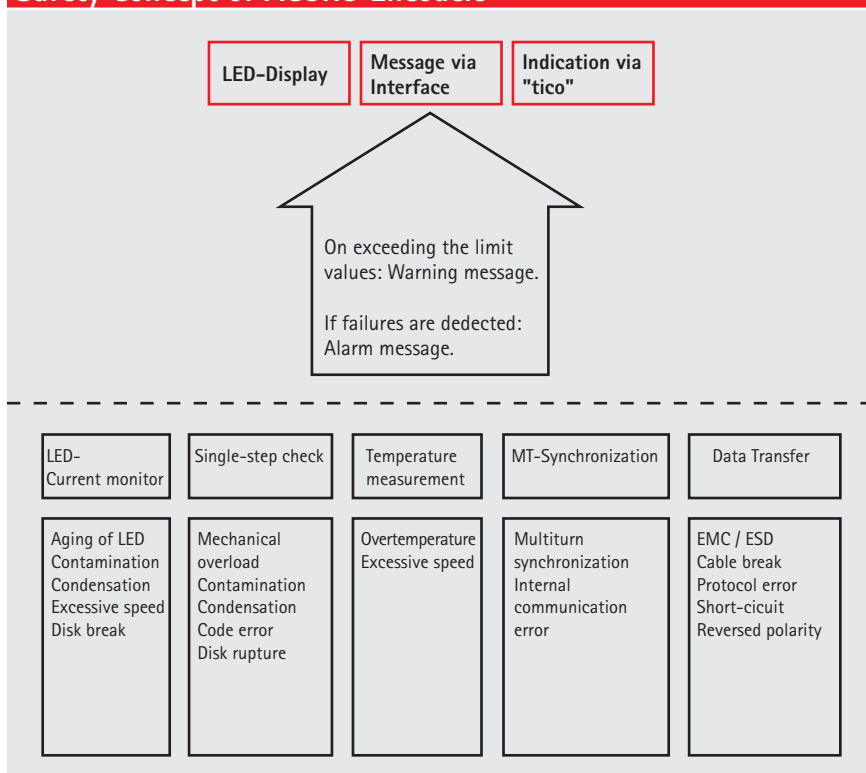



ACURO Industry: Absolute Encoders for Industrial Applications

Industrial adaptive encoders are used in a variety of applications such as printing and packaging machines, elevators and wind power generation plants.

Features of ACURO industry

- Compact design: 50 mm length for singleturn or multiturn versions
- Startup and operating aids: Diagnostics LED, preset key with optical feedback, status message
- Interfaces: Standard SSI, extended SSI mode, parallel interface or BiSS
- Sine/cosine signals available for dynamic control loops

Fieldbus Versions

- Overall length: 63 mm (singleturn), 73 mm (multiturn) including bus cover
- Availability of all common field bus interfaces
- The complete bus-specific electronics is accommodated in the bus cover
- Versions: Profibus DP, DeviceNet, CAN, CANopen and Interbus
- Optional: "tico"-indicator



Indicator "tico" for diagnosis and position indication

**ACURO industry:
Fast and easy installation**

ACURO industry with fieldbus allows fast and trouble-free installation. A compact 5-pin connector between the bus cover and encoder ensures easy access to the switches and address settings, even if the bus cable is connected. Bus cables can be mounted quickly into reliable cage clamps for wire cross-sections up to 1.5 mm². Optionally, a small external indicator unit (tico 731) can be connected via a 4 pin M12 connector to the encoder to read out the bus node address, diagnostic messages and current position values during installation or operation.



ACURO industry

Safety in machinery operations

Thanks to a common platform for industrial adaptive encoders and motor encoders, ACURO industry encoders benefit from the excellent speed and temperature range of the OptoASIC sensor, which has been specially designed for use in servo motors. The ACURO safety concept determines whether any limit values have been exceeded and generates early warning messages or alarms - a feature that enhances reliability and confidence in day-to-day machinery operations.

The number of components and solder joints has been minimized by using highly integrated circuits and simulation-optimized gears for the multiturn version - a feature that ensures a high degree of long-term operating safety.

Full compatibility

All ACURO encoders are fully backward-compatible with:

- Sine/Cosine- 1V_{ss} peak-to-peak
- Standard SSI interface
- Parallel or fieldbus interface



ACURO soft

Maximum configuration flexibility

ACURO soft is a Windows-based parameterization software for our new encoder family. It allows fast on-site configuration (e.g. using a notebook) of all important operating parameters, such as resolution, scaling, sense of rotation, reset, offset, as well as the warning and alarm functions. All these parameters can be configured according to your individual requirements.



ACURO drive: Absolute Encoders for Motor Feedback Applications

ACURO drive – for truly digital drives

ACURO drive is used in brushless high-performance motors and multi-pole direct drives. For the first time, dynamic servo drives have become fully digital. ACURO drive transmits up to 22 bits/turn using BiSS without requiring any of the analog sine signals that were needed up until now. The design of ACURO drive is focused on its ability to cope with the harsh operating conditions within the motor housing. It can be used at operating temperatures from -15°C up to +120°C and speeds of 10,000 rpm in continuous operation.

Motor Encoder Features

- Fully digital and high-speed
- +120°C operating temperature
- 10,000 rpm continuous operation
- Geared optical multiturn
- SSI or BiSS interface
- Option: Sine 1V peak-to-peak option
Harmonic distortion less than 1%
- Bandwidth 500 kHz



ACURO drive

ACURO drive Multiturn concept for enhanced interference immunity

The multiturn version of ACURO drive ensures optical detection of the number of revolutions – an important feature for direct use on the motor axes.

An example: Motor brakes and windings often generate strong magnetic fields, which may cause interference with magnetic measuring systems. The optical scanning feature of ACURO drive offers an additional safety factor to counter these effects.

BiSS Sensor Communication

Bi-directional and fully-digital

BiSS is a new, fully-digital and bi-directional sensor interface. It defines communication between one master and several slaves (sensors) in industrial control systems. BiSS manifests a new standard in technology and is available license-free (GPL). Due to its high performance, it constitutes an efficient alternative to the standard combination of data interface and analog sine/cosine incremental output.

BiSS only needs a total of 6 lines (4 data, 2 power), does not require any hardware for analog signals (cable(s)/drive interpolation electronics) – and so helps to reduce system costs.

Bus Networking:

Up to 8 sensors can be connected to a bus-master. Wiring and control cost is considerably reduced for multi-axe applications.

For more information about BiSS as well as implementation support please check www.biSS-interface.com.

Benefits of BiSS:

- Eliminates the costs of interpolation electronics
- Offering a high degree of transmission reliability
- Representing the only fully digital, open motor feedback interface for real-time applications.



ACURO drive

Technical Data ACURO industry

Version SSI/BiSS

HENGSTLER

	Acuro industry	Acuro drive
Electrical		
Supply voltage	5V, -5% / +10% or 10 – 30V	5V, -5% / +10%
Intrinsic current consumption ST/MT	50 mA / 100 mA	50 mA / 100 mA
Interface	Standard SSI or BiSS	Standard SSI or BiSS
Lines / Drivers	Clock and data / RS422	Clock and data / RS422
Output code	Binary or Gray; parameterization via Acuro soft	Binary or Gray; parameterization via Acuro soft
Singleturn resolution	10 – 17 bits depending on version; max 13 bits in SSI-MT Gray Excess: 360, 720 steps	13 bits (SSI) 22 bits (BiSS)
Multiturn resolution	12 Bit	12 Bit
Incremental signals, optional	Sine – cosine 1 Vpp	Sine – cosine 1 Vpp
Number of increments	2,048	2,048
3dB limiting frequency	500 kHz	500 kHz
Absolute accuracy	± 35''	± 35''
Repeatability	± 7''	± 7''
Connection	Cable for flange-connector (Conin, axial or radial)	PCB pinheader 12p / 14p
Parameterization	Resolution, code type, sense of rotation, warning, alarm	Resolution, code type, sense of rotation, warning, alarm
Control input	<u>Direction</u>	–
Reset Key	Latch via parameterization	–
Alarm output	Alarm Bit (SSI option), warning Bit and alarm Bit (BiSS)	Alarm Bit (SSI option), warning Bit and alarm Bit (BiSS)
Status LED	Green = ok.; Red = Alarm	–
Mechanical		
Housing diameter	58 mm	58 mm
Protection, shaft input	IP 64 or IP 67	IP 40
IP Protection class, housing	IP 67	IP 40
Flange types	Synchro-flange, clamping flange, spring tether	Spring tether
Shaft diameter	Solid shaft 6 mm, 10 mm; Hub shaft 10 mm, 12 mm	Tapered shaft 10 mm
Max. speed	Continuous operation 10,000 min ⁻¹ , short-term 12,000 min ⁻¹	Continuous operation 10,000 min ⁻¹ , short-term 12,000 min ⁻¹
Starting Torque	≤ 0,01 Nm	≤ 0,01 Nm
Moment of inertia, rotor	3.8 x 10 ⁻⁶ kgm ²	3.8 x 10 ⁻⁶ kgm ²
Tolerance axial	± 1.5 mm	± 1.5 mm
Tolerance radial	± 0.2 mm	± 0.2 mm
Absolute max. shaft load	∅ 6 mm axial 60 N (13 lbs), radial 110 N (24 lbs) ∅ 10 mm axial 107 N (24 lbs), radial 60 N (35 lbs)	
Bearing life	1x10 ¹⁰ revolutions (typ.) at 35% of full rated shaft load 1x10 ⁹ revolutions (typ.) at 75% of full rated shaft load 1x10 ⁸ revolutions (typ.) at 100% of full rated shaft load for example 30,000 h at 6,000 RPM with a 13 lb radial load (10 mm shaft)	
Shock resistance DIN EN 60068-2-27	1,000 m/s ² (6 ms)	1,000 m/s ² (6 ms)
Vibration resistance DIN EN 60068-2-6	100 m/s ² (10 ... 2,000 Hz)	100 m/s ² (10 ... 2,000 Hz)
Operating temperature	-40...+100 °C	-15...+120 °C
Storage temperature	-40...+85 °C	-15...+85 °C (due to packaging)
Weight, approx. (ST / MT)	260 g / 310 g	260 g / 310 g

Ordering Data ACURO industry BiSS

HENGSTLER

AC 58 / 1212 E K.42 BC H

Resolution	Supply voltage	Flange	Protection	Shaft-Ø	Interface	Connection
0010 10 Bit ST	A = 5V	S. 41 Synchro	IP 64	6 mm	BI = BiSS (Digital)	A = Cable axial
0012 12 Bit ST	E = 10-30V	S. 71 Synchro	IP 67	6 mm	BC = BiSS (+SinCos 1Vss)	B = Cable radial
0013 13 Bit ST		K. 42 Clamping	IP 64	10 mm		C = Conin 12p. ax. cw
0014 14 Bit ST		K. 72 Clamping	IP 67	10 mm		D = Conin 12p. rad. cw
0017 17 Bit ST		F. 42 Spring tether	IP 64	10 mm Hub shaft		G = Conin 12p. ax. ccw
0360 360 increments ST		F. 47 Spring tether	IP 64	12 mm Hub shaft		H = Conin 12p. rad. ccw
0720 720 increments ST						7 = M12, 8p. axial
1212 12 Bit MT + 12 Bit ST						8 = M12, 8p. radial
1213 12 Bit MT + 13 Bit ST						
1214 12 Bit MT + 14 Bit ST						
1217 12 Bit MT + 17 Bit ST						

PC connection cable for ACURO soft, including power pack 230 VA, for 12p. Conin, CCW (suitable for G and H), Code No. 1 565 053.

Ordering Data ACURO industry SSI

AC 58 / 1212 E K.42 SG H

Resolution	Supply Voltage	Flange	Protection	Shaft-Ø	Interface	Connection
0010 10 Bit ST	A = 5V	S. 41 Synchro	IP 64	6 mm	SB = Serial Binary	A = cable axial
0012 12 Bit ST	E = 10-30V	S. 71 Synchro	IP 67	6 mm	SG = SSI Gray	B = cable radial
0013 13 Bit ST		K. 42 Clamping	IP 64	10 mm		C = Conin 12p. ax. cw
0014 14 Bit ST		K. 72 Clamping	IP 67	10 mm		D = Conin 12p. rad. cw
0017 17 Bit ST		F. 42 Spring tether	IP 64	10 mm Hub shaft		G = Conin 12p. ax. ccw
1212 12 Bit MT + 12 Bit ST		F. 47 Spring tether	IP 64	12 mm Hub shaft		H = Conin 12p. rad. ccw
1213 12 Bit MT + 13 Bit ST						7 = M12, 8p. axial
						8 = M12, 8p. radial

PC connection cable for ACURO soft, including power pack 230 VA, for 12p. Conin, CCW (suitable for G and H), Code No. 1 565 053.

Ordering Data ACURO drive SSI/BiSS

HENGSTLER

AD 58 / 1213 A 1 . 0 K SC O

Resolution
0013 13 Bit ST (SSI)
0022 22 Bit ST (BiSS)
1213 12 Bit MT + 13 Bit ST (SSI)
1222 12 Bit MT + 22 Bit ST (BiSS)

Supply voltage
A = 5V
G = 7-12V

Protection
0 = IP40

Shaft-Ø
K = 10 mm conical male

Interface
SC = SSI Gray + 1Vpp
BI = BiSS (Digital)

Connection
O = PCB connector 12 pol.
B = PCB 12 pol. with mating connector and 0.5 m Cable

Flange
1 = Spring tether

PC connection cable for ACURO soft, including power pack 230 VA, for 12p. Conin, CCW (suitable for G and H), Code No. 1 565 055.

Dimensions ACURO drive SSI/BiSS

Tapered Shaft

Central fixing screw
 Multiturn: DIN 912 M5x65
 Singelturn: DIN 912 M5x50

All dimensions in mm

Technical Data ACURO industry

Version-specific Data – Parallel Interface

HENGSTLER

Electrical	
Supply voltage	10-30V
Intrinsic current consumption	200 mA / 300 mA
Interface	Parallel
Output code	Binary, Gray, Gray Excess
Resolution Singleturn	10 – 14 Bit depending on version 12 Bit in MT version Gray Excess: 360, 720 steps
Resolution Multiturn	12 Bit
Linearity	± 1/2 LSB
Output current	30 mA per Bit, short circuit proof
Alarm output	NPN o.c. max 5 mA
Control inputs	Latch, Direction, Tristate
Connection	Cable or flange-connector (Conin 17-pole), axial or radial, Sub-D 37-pin
Mechanical	
Weight (approx.) ST / MT	350 g / 400 g

Note: Preset key only with MT

Ordering Data ACURO industry Parallel Interface

AC 58 / 1212 E K.42 PB A - A1 - F

Resolution	Supply Voltage	Flange	Protection	Shaft-Ø	Interface	Connection
0010 10 Bit ST	E = 10-30V	S. 41 Synchro	IP 64	6 mm	PB = Parallel Binary	A = Cable axial (ST, MT)
0012 12 Bit ST		S. 71 Synchro	IP 67	6 mm	PG = Parallel Gray	B = Cable radial (ST, MT)
0013 13 Bit ST		K. 42 Clamping	IP 64	10 mm		U = Conin 17p. axial CCW (ST)
0014 14 Bit ST		K. 72 Clamping	IP 67	10 mm		V = Conin 17p. radial CCW (ST)
0360 360 increments ST		F. 42 Spring tether	IP 64	10 mm Hub shaft		W = Conin 17p. axial CW (ST)
0720 720 increments ST		F. 47 Spring tether	IP 64	12 mm Hub shaft		Y = Conin 17p. radial CW (ST)
1212 12 Bit MT + 12 Bit ST						A-A1-F = 0,1m Cable axial + 37 pol. Sub-D (MT) B-A1-F = 0,1m Cable radial + 37 pol. Sub-D (MT)

Note: Maximum cable length at the encoder is 3m.
For longer cable please use extension cables published in our encoder catalogue.

Technical Data ACURO industry

Version-specific Data – Profibus

HENGSTLER

Electrical	
Supply voltage	10 – 30 V
Intrinsic current consumption	220 mA / 250 mA
Interface	Profibus-DP, Encoder Profile
Certified	PNO
Programmable	According to Class 2: Resolution, Preset, Direction
Output code	Binary
Baudrate	9,6 kBaud – 12 MBaud
Resolution Singleturn	10 – 14 Bit depending on version
Resolution Multiturn	12 Bit
Integrated Special functions	Speed, Acceleration, Operating Time
Connection	Bus cover with T-manifold
Mechanical	
Operating temperature	-40 °C to +85 °C
Weight (approx.) ST / MT	350 g / 400 g

Note: Preset only via bus, no key.

Ordering Data ACURO industry Profibus

AC 58 / 1212 E K.42 DP Z						
Resolution	Supply voltage	Flange	Protection	Shaft-Ø	Interface	Connection
0010 10 Bit ST	E = 10-30V	S. 41 Synchro	IP 64	6 mm	DP = Profibus DP	Z = Bus cover 3x cable gland
0012 12 Bit ST		S. 71 Synchro	IP 67	6 mm		T = Bus cover 4 pol. M12
0013 13 Bit ST		K. 42 Clamping	IP 64	10 mm		for "tico"-indicator + 2x cable gland
0014 14 Bit ST		K. 72 Clamping	IP 67	10 mm		
1212 12 Bit MT + 12 Bit ST		F. 42 Spring tether	IP 64	10 mm Hub shaft		
1213 12 Bit MT + 13 Bit ST		F. 47 Spring tether	IP 64	12 mm Hub shaft		
1214 12 Bit MT + 14 Bit ST						

Note:
 Bus Connections radial/axial via connector and cable, optional on request.

- **Diagnosis Kit** 230 VAC for encoder with bus cover, incl. ACURO soft and "tico" indicator, Art. No. 1 565 070
- "tico"-indicator, Art. No. 0 731 205
- Connection cable bus cover (T) to "tico", 1.5m, Art. No. 3 539 575

Technical Data ACURO industry

Version-specific Data – Devicenet

HENGSTLER

Electrical	
Supply voltage	10 – 30V
Intrinsic current consumption ST/MT	220 mA / 250 mA
Interface	CAN Highspeed according ISO/DIS 11898, CAN Specification 2.0 B (11 and 29 Bit identifier)
Protocol	Manufacturer specific profile, based on encoder profile draft DeviceNet
Programmable	According to Class 2: Resolution, Preset, Direction
Output code	Binary
Transfer mode	Pollmode (only on request), Change of State (automatically when values change), Cyclic with adjustable cycle timer
Baudrate	Settable 125, 250, 500 KBAud
Resolution Singleturn	10 – 14 Bit, depending on version, 12 Bit for multiturn version
Resolution Multiturn	12 Bit
Connection	Bus cover with T-manifold
Mechanical	
Operating temperature	-40 °C to +85 °C
Weight (approx.), ST / MT	350 g / 400 g

Ordering Data ACURO industry DeviceNet

AC 58 / 1212 E K.42 VD Z

Resolution	Supply voltage	Flange	Protection	Shaft-Ø	Interface	Connection
0010 10 Bit ST	E = 10-30V	S. 41 Synchro	IP 64	6 mm	VD = DeviceNet	Z = Bus cover 2x cable gland
0012 12 Bit ST		S. 71 Synchro	IP 67	6 mm		T = Bus cover 4 pol. M12
0013 13 Bit ST		K. 42 Clamping	IP 64	10 mm		for "tico"-indicator + 2x cable gland
0014 14 Bit ST		K. 72 Clamping	IP 67	10 mm		
1212 12 Bit MT + 12 Bit ST		F. 42 Spring tether	IP 64	10 mm Hub shaft		
1213 12 Bit MT + 13 Bit ST		F. 47 Spring tether	IP 64	12 mm Hub shaft		
1214 12 Bit MT + 14 Bit ST						

Note:
Bus Connections radial/axial via connector and cable, optional on request.

- **Diagnosis Kit** 230 VAC for encoder with bus cover, incl. ACURO soft and "tico" indicator, Art. No. 1 565 070
- "tico"-indicator, Art. No. 0 731 205
- Connection cable bus cover (T) to "tico", 1.5m, Art. No. 3 539 575

Technical Data ACURO industry

Version-specific Data – CANopen / CAN Layer 2

HENGSTLER

Electrical	
Supply voltage	10 – 30 V
Intrinsic current consumption ST/MT	220 mA / 250 mA
Interface	CAN High-Speed according to ISO/DIS 11898, Basic- and Full-CAN, CAN-Specification 2.0 B (11 and 29 Bit Identifier)
Protocol	CANopen according to Profile DSP 406, with additional functions
Programmable	CANopen: Direction, Resolution, Preset, Offset, Limit Values; CAN L2: Direction, Limit Values
Output code	Binary
Transfer mode	Pollmode (only on request), Change of State (automatically when values change), cyclic with settable cycle timer
Baudrate	Adjustable 10 to 1,000 Kbaud
Base identifier	Settable via DIP switches
Resolution Singleturn	10 – 14 Bit, depending on version, 12 Bit for multiturn version
Resolution Multiturn	12 Bit
Special functions	Speed, Acceleration, Round shaft, Limit Values only for CANopen
Connection	Flange-connector socket (Conin 12-pole axial or radial), bus cover with T-manifold
Mechanical	
Operating temperature	-40 °C to +85 °C
Weight (approx.), ST/MT	350 g / 400 g

Ordering Data ACURO industry CANopen / CAN Layer 2

AC 58 / 1212 E K.42 OL Z

Resolution	Supply voltage	Flange	Protection	Shaft-Ø	Interface	Connection
0010 10 Bit ST	E = 10-30V	S. 41 Synchro	IP 64	6 mm	OL = CANopen	C = Conin 12p. ax. cw
0012 12 Bit ST		S. 71 Synchro	IP 67	6 mm	CL = CAN L2	D = Conin 12p. rad. cw
0013 13 Bit ST		K. 42 Clamping	IP 64	10 mm		Z = Bus cover 3x cable gland
0014 14 Bit ST		K. 72 Clamping	IP 67	10 mm		T = Bus cover 4 pol. M12
1212 12 Bit MT + 12 Bit ST		F. 42 Spring tether	IP 64	10 mm Hub shaft		for "tico"-indicator + 2x cable gland
1213 12 Bit MT + 13 Bit ST		F. 47 Spring tether	IP 64	12 mm Hub shaft		
1214 12 Bit MT + 14 Bit ST						

Note:
Bus Connections radial/axial via cable, optional on request.

- **Diagnosis Kit** 230 VAC for encoder with bus cover, incl. ACURO soft and "tico" indicator, Art. No. 1 565 070
- "tico"-indicator, Art. No. 0 731 205
- Connection cable bus cover (T) to "tico", 1.5m, Art. No. 3 539 575

Technical Data ACURO industry

Variant-specific Data – Interbus

HENGSTLER

Electrical	
Supply voltage	10 – 30V
Intrinsic current consumption ST/MT	220 mA / 250 mA
Interface	Interbus, ENCOM Profile K3 (parameterizable), K2
Programmable	Direction, Scaling Factor, Preset, Offset
Output code	32 Bit Binary
Baudrate	500 kBaud according to ENCOM
Data transfer	Supi address 0123, Byte Nr. 3210
ID.Code K3	37H (= 55 decimal)
Resolution Singleturn	10 to 17 Bit depending on version, 12 Bit for MT version
Resolution Multiturn	12 Bit
Connection	Bus cover with T-manifold
Mechanical	
Operating temperature	-40 °C to +85 °C
Weight (approx.), ST / MT	350 g / 400 g

Ordering Data ACURO industry Interbus

AC 58 / 1212 E K.42 I3 I						
Resolution	Supply voltage	Flange	Protection	Shaft-Ø	Interface	Connection
0010 10 Bit ST	E = 10-30V	S. 41 Synchro	IP 64	6 mm	I2 = Interbus K2	I = Double Conin 9p. rad cw
0012 12 Bit ST		S. 71 Synchro	IP 67	6 mm	I3 = Interbus K3	Z = Bus cover 3x cable gland
0013 13 Bit ST		K. 42 Clamping	IP 64	10 mm		T = Bus cover 4 pol. M12
0014 14 Bit ST		K. 72 Clamping	IP 67	10 mm		for "tico"-indicator + 2x cable gland
1212 12 Bit MT + 12 Bit ST		F. 42 Spring tether	IP 64	10 mm hollow shaft		
		F. 47 Spring tether	IP 64	12 mm hollow shaft		

Note:
Bus Connection radial/axial via cable, optional on request.

- **Diagnosis Kit** 230 VAC for encoder with bus cover, incl. ACURO soft and "tico" indicator, Art. No. 1 565 070
- "tico"-indicator, Art. No. 0 731 205
- Connection cable bus cover (T) to "tico", 1,5m, Art. No. 3 539 575

Synchro Flange

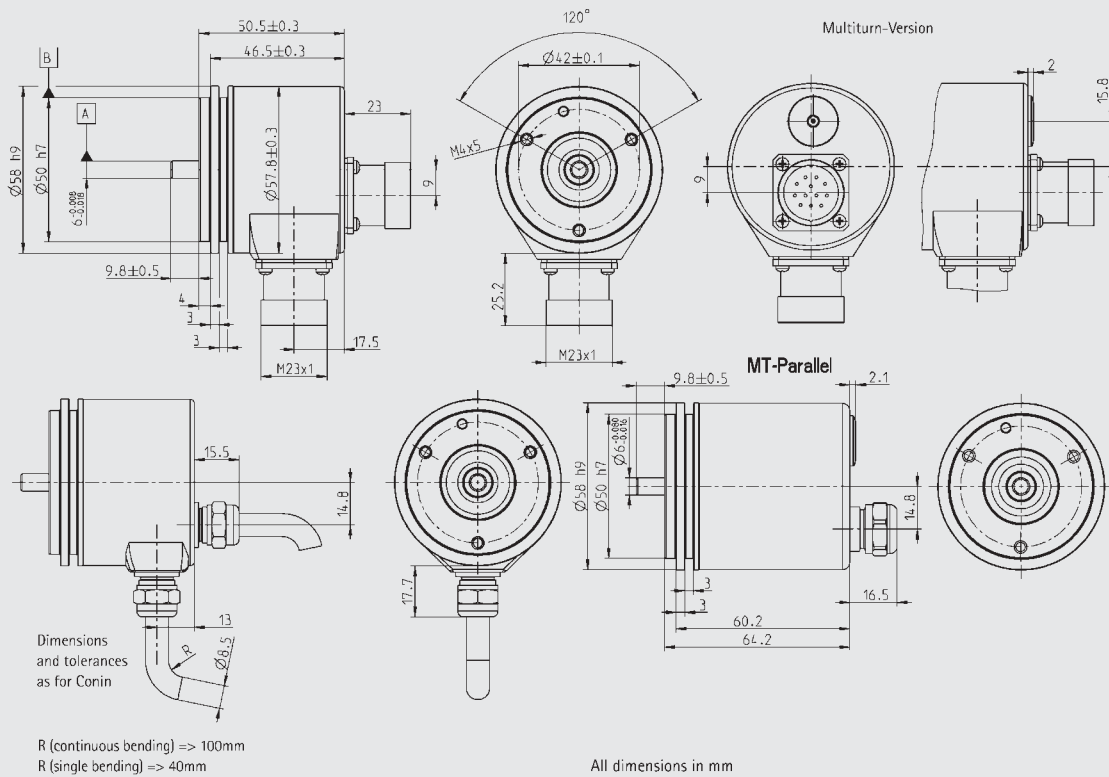

Clamping Flange

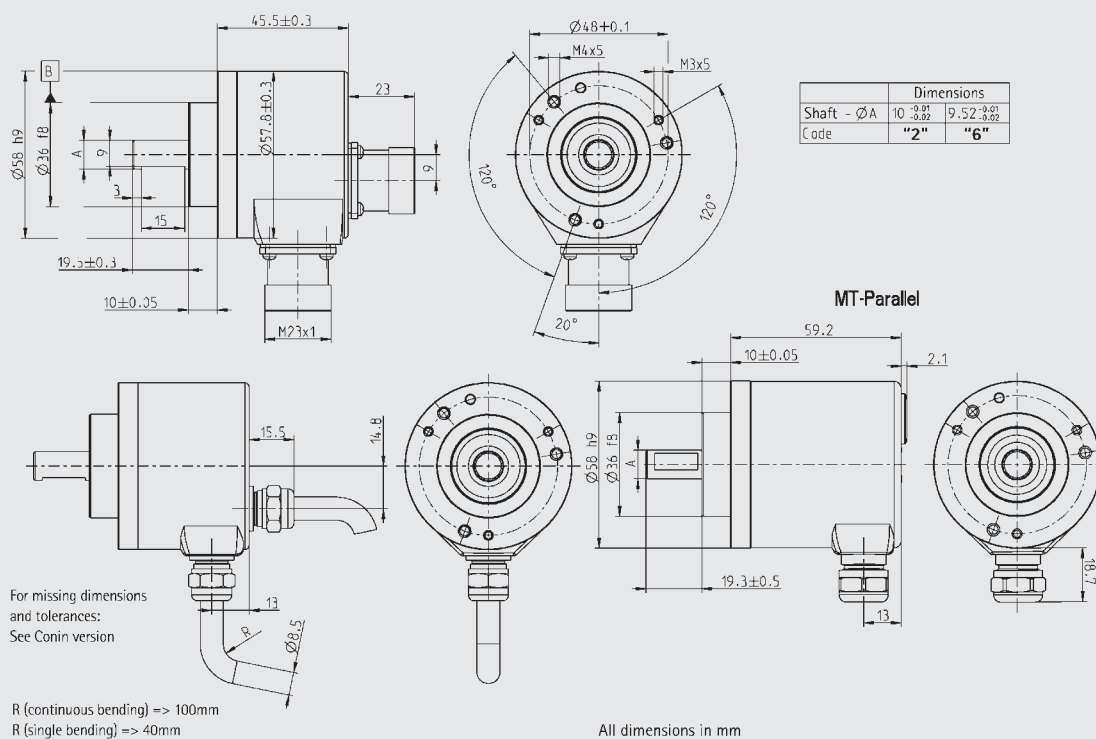

Hub Shaft

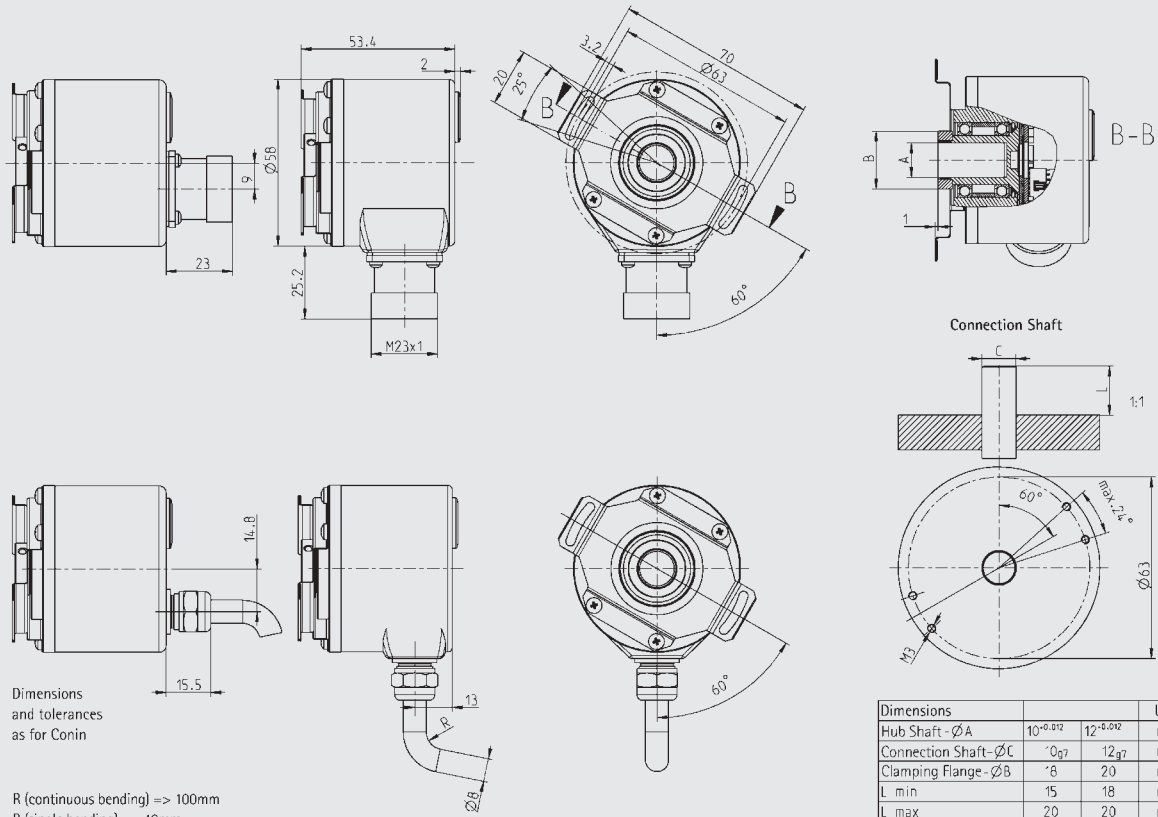

Dimensions			Unit
Hub Shaft - $\varnothing A$	$10^{+0.012}$	$12^{+0.012}$	mm
Connection Shaft - $\varnothing C$	$8^{+0.07}$	$12_{-0.07}$	mm
Clamping Flange - $\varnothing B$	8	20	mm
L min	15	18	mm
L max	20	20	mm

L = Depth of insertion of connection shaft in encoder

Bus Covers

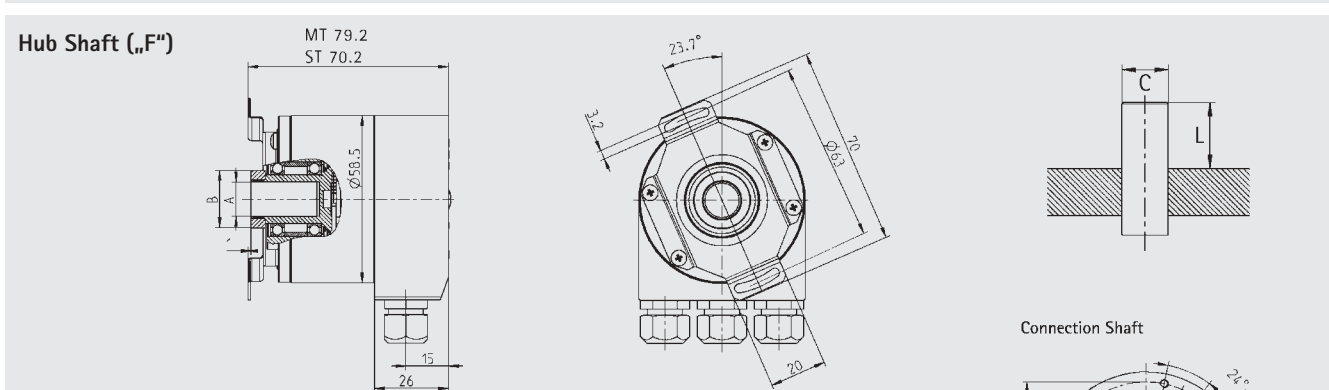
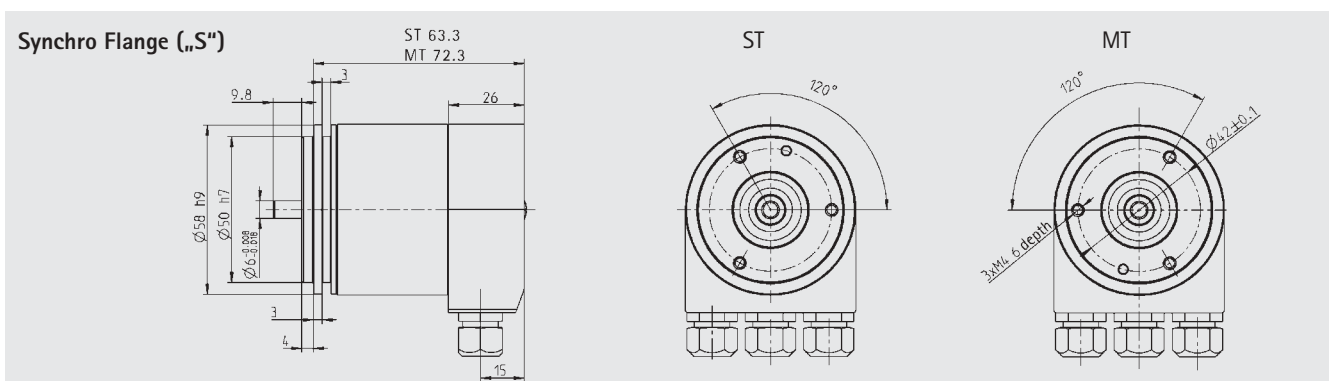
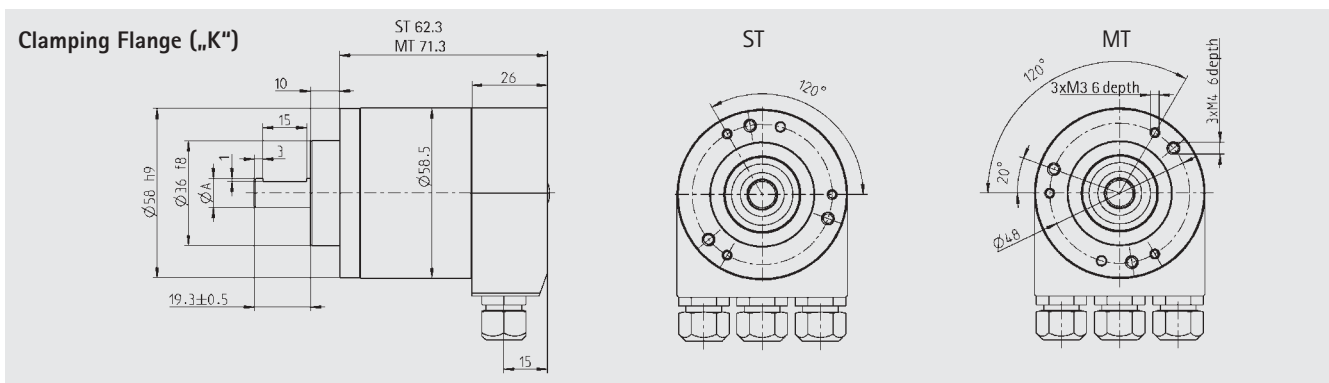
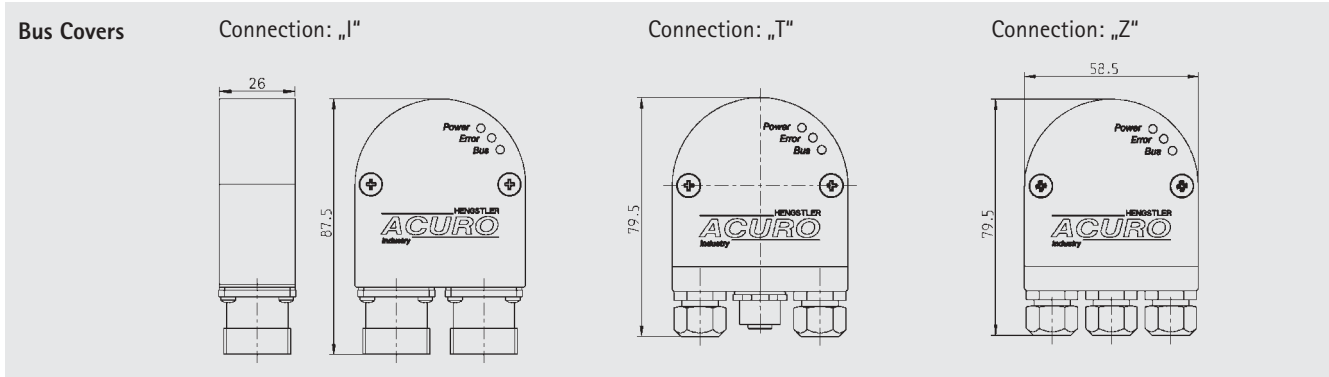

Dimensions

	Dimensions		Unit
Hub Shaft - $\varnothing A$	10 ^{+0.012}	12 ^{+0.012}	mm
Connection Shaft - $\varnothing C$	10 ^{+0.07}	12 ^{+0.07}	mm
Clamping Flange - $\varnothing B$	18	20	mm
L min.	15	18	mm
L max.	20	20	mm
Shaft Code	"2"	"7"	

L = Depth of insertion of connection shaft in encoder

ACURO industry

Overview Functions and Versions

HENGSTLER

	SSI	BiSS	Parallel ST	Parallel MT	Profibus	DeviceNet	Interbus K3	CAN	CANopen
Electrical									
Supply 5VDC	(Option)	•							
Supply 10-30VDC	•	•	•	•	•	•	•	•	•
Preset Key /w LED (not IP67)	•	•	LED only	•					
Diagnostics									
- LED-Indicators (Bus cover)					•	•	•	•	•
- Warning Bit		•			•				
- Alarm Bit	(Option)	•			•	•	•	•	•
- Alarm Output	(Option)	(Option)	•	•					
- Temperature Measuring	(Option)	•							
Connection for "tico"					•	•	•	•	•
Programmable (PC, over Parallel Port)	•	•			•	•	•	•	•
Programmable (over Bus)					•	•	•	•	•
Inputs									
- Latch only Binary			•	•					
- Direction	•	•	•	•					
- Tristate			•	•					
Special Functions									
- Speed					•			•	•
- Acceleration					•			•	•
- Hour Meter					•				•
- Round Axis									•
- Limit Values									•
Optional 1 Vpp signal	•	•							
Connections									
Bus cover 3 PG					•	•	•	•	•
Bus cover 2 PG +M12 f. "tico"					•	•	•	•	•
Bus cover 2 x PG						•			
Bus cover 2 x Conin 9p.							•		
Cable Ax/Rad	•	•	•	•					
Cable Ax / Rad 0.1m+37p. Sub-D				•					
Conin 9p. Ax/Rad CW / CCW							•		
Conin 12p. Ax/Rad CW / CCW	•	•						•	•
Conin 17p. Ax/Rad CW / CCW			•						
M12 8p. Ax/Rad	•	•							
Mechanical									
Synchro Flange, Shaft 6 x 10 mm, IP64 or IP67	•	•	•	•	•	•	•	•	•
Clamping Flange, Shaft 10 x 19.5 mm, IP64 or IP67	•	•	•	•	•	•	•	•	•
Hub Shaft 10 mm, Spring tether, IP64	•	•	•	•	•	•	•	•	•
Hub Shaft 12 mm, Spring tether, IP64	•	•	•	•	•	•	•	•	•

■ Germany
Hengstler GmbH
Uhlandstr. 49
78554 Aldingen
Tel. +49-74 24-8 90
Fax +49-74 24-8 94 70 / 89 500
E-mail: info@hengstler.de
<http://www.hengstler.com>

■ France
Hengstler Contrôle Numérique
S.A.R.L.
Z.I. des Mardelles
94-106, Rue Blaise Pascal, B.P. 71
93602 Aulnay-sous-Bois, Cédex
Tel. (01) 48795501
Fax (01) 48795561
<http://www.hengstler.com>

■ Great Britain
West Instruments
The Hyde
Brighton, East Sussex
BN2 4JU, England
Tel. +44 (0) 1273 606271
Fax +44 (0) 1273 609990
E-mail: info@west-inst.co.uk
<http://www.westinstruments.com>

■ Brasil
Veeder Root do Brasil
Com. e. Ind. Ltda.
Rua Ado Benatti, 92
Sao Paulo SP
CEP 05037-904
Tel 0055 11 361 121 55
Fax 0055 11 36 11 982
E-mail: Antonio_Araujo@veeder.com

■ Italy
ICG Holding S.r.l.
Via Leonardo da Vinci, 45/47
20020 Lainate (MI)
Tel. 0039-02 9330011
Fax 0039-02 933001299
E-mail: info@icg-holding.com

■ Japan
Hengstler Japan Corp.
2-12-23, Minamikaneden
Suita-shi
Osaka 564-0044
Tel. (06) 63868001
Fax (06) 63865022
E-mail: mailmaster@hengstler.co.jp
<http://www.hengstler.co.jp/>

■ USA
Danaher Controls
1675 Delaney Road
Gurnee, IL 60031-1282
Tel. (847) 662.2666
Fax (847) 662.6633
E-mail: dancon@dancon.com
<http://www.dancon.com>

AGENTS

Argentina, Australia, Austria, Belgium, Bulgaria, Brazil, Chile, China, Colombia, Czech Republic, Denmark, Egypt, Finland, Great Britain, Greece, Guatemala, Hong Kong, Hungary, India, Indonesia, Iran, Ireland, Israel, Kenya, Korea, Lebanon, Luxemburg, Malaysia, Mexico, Netherlands, New Zealand, Norway, Pakistan, Peru, Philippines, Poland, Portugal, Romania, Singapore, Slovenia, Slovak Republic, South Africa, Spain, Sweden, Switzerland, Taiwan, Thailand, Turkey, United Arab Emirates, USA, Venezuela

HENGSTLER

Hengstler GmbH
Uhlandstrasse 49
D-78554 Aldingen/Germany
Tel. +49 74 24-89 0
Fax +49 74 24-89 500
E-mail: info@hengstler.com
<http://www.hengstler.com>



DQS-certified according to DIN
EN ISO 9001, Reg. No. 1540-01



www.hengstler.de

All details are only intended as descriptive text and do not represent any binding assurances relating to the features described. We reserve the right to make modifications.

DOC 1248.02 E

Acuro-Brochure · 04/2003 · Printed in Germany – Printed on paper of non-pollutable, chlorine-free, non-acid production.